

A Shop-floor Kaizen Breakthrough Approach to Improve Working Environment and Productivity of a Sewing Floor in RMG Industry

Md. Abdul Quddus

Department of Industrial Engineering and Management
Khulna University of Engineering & Technology

A.M.M. Nazmul Ahsan

Department of Industrial Engineering and Management
Khulna University of Engineering & Technology
Bangladesh

ABSTRACT

Kaizen, a continuous improvement of process, is often considered to be the building block of all lean production methods. Kaizen focuses on eliminating waste, improving productivity and achieving sustained continual improvement in targeted activities and processes of an organization. Kaizen is not implemented vastly in garments industries. There is a tremendous scope of using kaizen in garments industries. This paper's objective is to show the effects of using kaizen in garments industries. The aim was to reduce Work In Progress (WIP) and to improve the working environment so as to improve productivity. Kaizen was implemented as a short term project in a sewing floor of a RMG industry and the effects was investigated during implementation. Implementing kaizen in sewing floor, the productivity has been increased while wastes and defects are reduced. The KAIZEN implementation reduced Defects per Hundred Units. This paper emphasizes on the continuous improvement in readymade garments industries.

Keywords: Kaizen, Lean Manufacturing, Non value-added activity, Line Efficiency, 5S score

1. INTRODUCTION

The apparel industry is one of the pillar industries of Bangladesh. According to World Trade Reports (2008), Bangladesh is the 3rd largest apparel exporting country in the world. The Readymade Garments (RMG) industry is the largest single economic sector in Bangladesh which contributes to 76% of national exports and 90% of manufacturing goods exports (Export Promotion Bureau, 2007). The garment industry is highly labor-intensive and employs approximately two million

workers, out of which 90 per cent are women (United Nation Industrial Development Organization, 2009). As employees are focused on stitching operations they tend to get injured when there is a lapse in attention (Kumar and Naidu, 2012). Therefore, Bangladesh has around 70 million of available low cost workers who could be easily trainable and engaged in the apparel sector (Mohiuddin, 2009). As the garments industries are labor intensive the best utilizing of labors of the industry will assure the highest profit of company. Lean production is founded on the

idea of kaizen or continual improvement. This philosophy implies that small incremental changes routinely applied and sustained over a long period result in significant improvements. Using lean, continuous improvement is done dramatically. In addition to this lean production involves, motivates and develop employee skills through education and multi-skilling program (Ferdousi and Ahmed, 2009). Lean assures the best utilization of labors. Also, in order to increase productivity, the organizations intentionally or unintentionally should use 5s system completely or at least a part of it which will completely ensure the organizations to achieve a better performance of their system (Hojjati, 2011). Womack et al. (1990) suggested that Lean assures the best utilization of labors and information management could be made much simpler and more accurate in the system.

2. BACKGROUND

Transforming raw materials and information into parts or products which the customer wants is called Value-Adding Activities. Which consume resources, but don't directly contribute to the product are called Non-Value-Adding Activities. A major concern of lean manufacturing is to reduce these Non-Value-Adding activities that badly decrease the productivity. Moreover, according to lean principle, there are seven types of wastes in manufacturing such as defective products, overproduction, inventories, excess motion, processing, transportation and waiting. Without question, best practices should be captured and standardized; the absolute goal is kaizen, to identify muda, or waste, and continually develop processes (Hall, 2013). Kaizen acts as a tool that helps reduce these wastes and Non-Value-Adding activities and thus leads to improved productivity. Kaizen Breakthrough is the team-based energy and creativity drives immediate process improvement.

2.1 Shop-floor Kaizen Breakthrough

Kaizen is a Japanese word meaning gradual, orderly, continual improvement or change for better (Kaur, 2014). Kaizen has become a part of the Japanese manufacturing system and has contributed enormously to the manufacturing success (Singh and Singh, 2009). Kaizen Breakthrough is a cross-functional, team-based process for rapid improvement. It is the process of fast change through involvement. The Kaizen Breakthrough Methodology is a short term like a five-day improvement project conducted on shop floor or office to help identify wastes and reconfigure operations to achieve more streamlined, value added processes. The philosophy of kaizen, which simply means continuous improvement, is the starting place for all lean production improvements. Kaizen events are opportunities to make focused changes in the workplace. Kaizen for the Shop floor takes through the critical steps in conducting a very effective kaizen event one that is well planned, well implemented, and well documented. At the end of a kaizen breakthrough event these teams typically achieve double-digit reductions in lead time, inventory, defects, and floor space and 25 to 50 percent increases in productivity. The principles of Shop-floor Kaizen Breakthrough (SKB) are-

- Clear objectives
- Team process
- Tight focus on time (one week)
- Quick and simple, action first
- Necessary resources available right away
- Immediate results (new process functioning by end

3. METHODOLOGIES

The implementation of Kaizen is that it works on a small area and works on a small change to improve the overall productivity. The Kaizen implementation event was a five days activity. A sewing line named YHT-02(B) of Youngone Sportswear Hi-tech Company Limited, DEPZ, Savar, Dhaka had

been selected for implementation. The style no. 376819 ordered by NIKE was sewing on that line. Total summarizations of Kaizen implementation are given below-

- Lean training to the operator, line supervisor and other relevant persons.
- Existing data collection and finalizing objectives.
- Audit of 5S of existing layout and taking corrective action plan. Auditing 5S after taking these corrective actions.
- Taking quality actions by identifying top 5 defects of current sewing line. Identifying root causes of these defects and taking corrective action plans to reduce these top 5 defects.
- Taking some maintenance actions such as daily checklists for operators and technicians to reduce uncertain breakdown and bad quality.

- Visualizing hour & hour chart of the sewing line.

3.1 Industry Application

The existing layout of the line is illustrated in the Figure 1. Here it shows that the line is so complicated and complex to understand. It is not a simple flow of garments. There was a lot of excess flow of garments. So the cycle time should be balanced and standardized the operation to reduce these non-value added motion and to assign a smooth layout. In the existing layout there were 32 operators for whom 32 machine were assigned. A new layout is proposed after implementing standard operation procedure and cycle time balancing is illustrated in Figure 2.

J
T
A
T
M

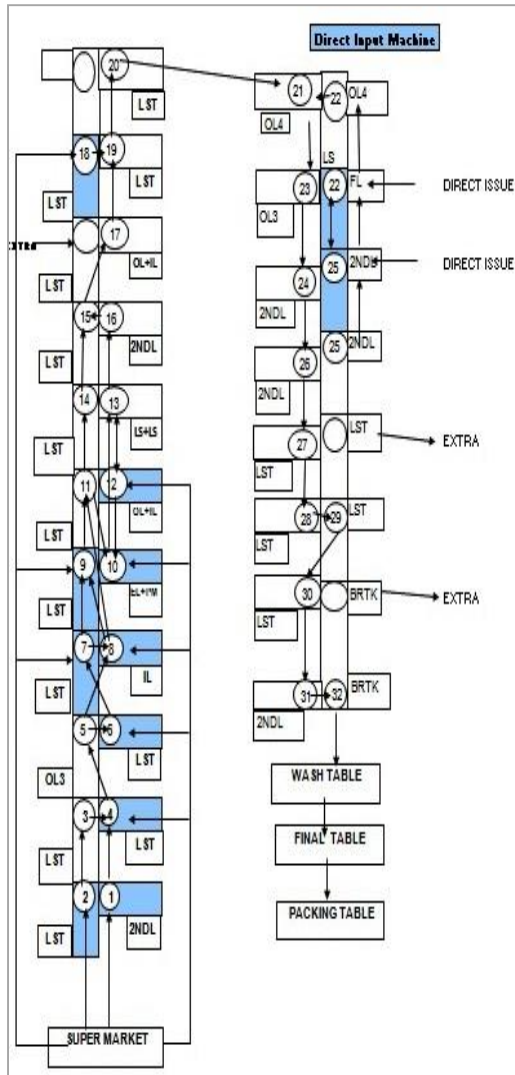

Figure 1. Layout of existing line

Here the unnecessary material flow is reduced. Here the two parts of the garments are simultaneously starts by two different machines named LS and 2NDL machine. The two parts are combined in the LST machine (process no. 4). Similarly the other operations are done one by one machine. In the line one operator named 28 is eliminated because there are similar machines sequences. Jobs of the operator 28 were distributed among the operators 27, 28 and 29 of new layout.

On the first day, the first task of implementing Kaizen was to train the operator, line supervisor and other relevant

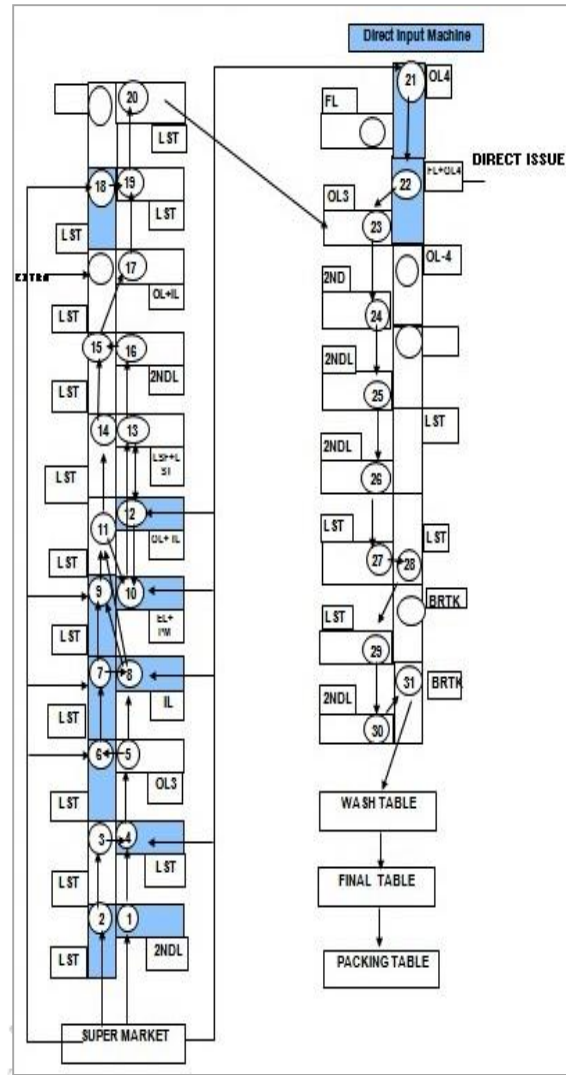

Figure 2. Proposed layout of line

A
T
M

persons about Lean, Kaizen and other necessary information. 5S is a process and method for creating and maintaining a safe, organized, clean and high-performance workplace. It is a conditioning discipline for kaizen. 5S works on the working environment of the garments. The name of factors and their descriptions are listed in Table 1. The 5S score evaluation & scoring criteria are that five or more than five problems are considered as zero score. Four problems are considered as one score. Similarly three problems, two problems, one problem and zero problems are considered as two score, three score, four score and five score respectively.

Work In Progress (WIP) is one of the fundamentals in building a 'Lean' environment in a business. It is often an overlooked part of the practice to reduce lead times and increase factory performance. WIP is one of the key performance indicators which directly influence various areas of production. WIP costs money (material, labor and overheads) to produce and excess WIP means an excess of working capital tied up in a resource that is not

adding any value. Work in Progress (WIP) of garments can be expressed in the number of pieces by simply recording daily production figures between each process and accumulating the difference between sequential processes. For example, if 10,000 pieces are be cut but only 6,000 pieces are sewed then WIP in sewing will have to be reduced by 4,000 pieces on that day. On the first day, the observed existing WIP of the line was 152 pieces of garments.

Table 1. 5S score sheet before kaizen implementation

Sl. No.	Factors	Score	Note for the next level of improvement
01	Unnecessary Items	1	1. Found previous defective Garments 2. Found unnecessary yarn 3. Defective yarns were there 4. Unnecessary fabrics were present
02	Safety	3	1. Boxes were not in their position. 2. Large items were stored incorrectly
03	Material Storage	2	1. Defective garments were stored in the tray 2. Previously other items of defective garments were present 3. Unnecessary fabrics were stored
04	Tools & Gages	3	1. No specific place for tools 2. Tools were not standardized
05	Cleaning Equipment & Materials	3	1. Brooms were stored in the tray 2. No specific place for brooms
06	Emergency Equipment	1	1. No specific point for emergency equipment 2. Emergency equipment were not colored 3. Not sufficient equipment 4. Emergency equipment were not maintained properly.
07	Aisles	3	1. Trays were present in aisles 2. Fabrics were present in the aisles
08	Floor (Cleaning)	2	1. Fabrics were present in the floor 2. Shoes were also present 3. Unnecessary yarns were found
09	Equipment (Cleanliness)	2	1. Dust in equipment 2. Unnecessary oil were always in the equipment 3. Work surface were not clean
10	Equipment (maintenance)	2	1. Dust in the equipment 2. Oil leakage in equipment 3. Dust in light code
11	Visual Management	0	No visual management
12	5S Control (Posted)	0	No 5S
Total		22	
5S Score		22/12 = 1.83	

The main objective of lean is to reduce wastes. In sewing floor defective garments are regarded as wastes. Defects are very common in sewing floor. So if defects are reduced wastes are also reduced. It also improves quality garments. There are different types of defects that can occur in sewing floor. But defects which occur frequently and respectively are to be given priority. So reduction in these defects will

results in reduction of total defects of sewing floor and so efficiency, productivity, and quality will increase dramatically. Data have been gathered of the previous week of Kaizen implementation from line YHT-2 B of Youngone Sportswear. Figure 3 shows the defects occurred in last one week. Here the defects broken stitch, wrong stitch, run off stitch, ironing, needle pick, pleat, skip stitch occur most times.

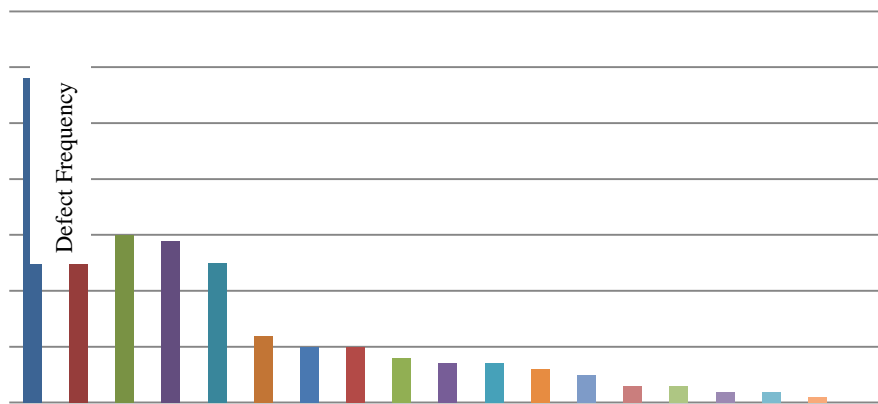

Figure 3. Defects of last one week in line YHT-2 B of Youngone Sportswear

The root cause analysis has been carried out for mostly occurring defects. Figure 4 exhibits the fish bone diagram of a defective garment. This fish bone diagram identifies

the causes of top five defects. To reduce these defects some corrective action plans are taken. Those corrective actions are listed in Table 2.

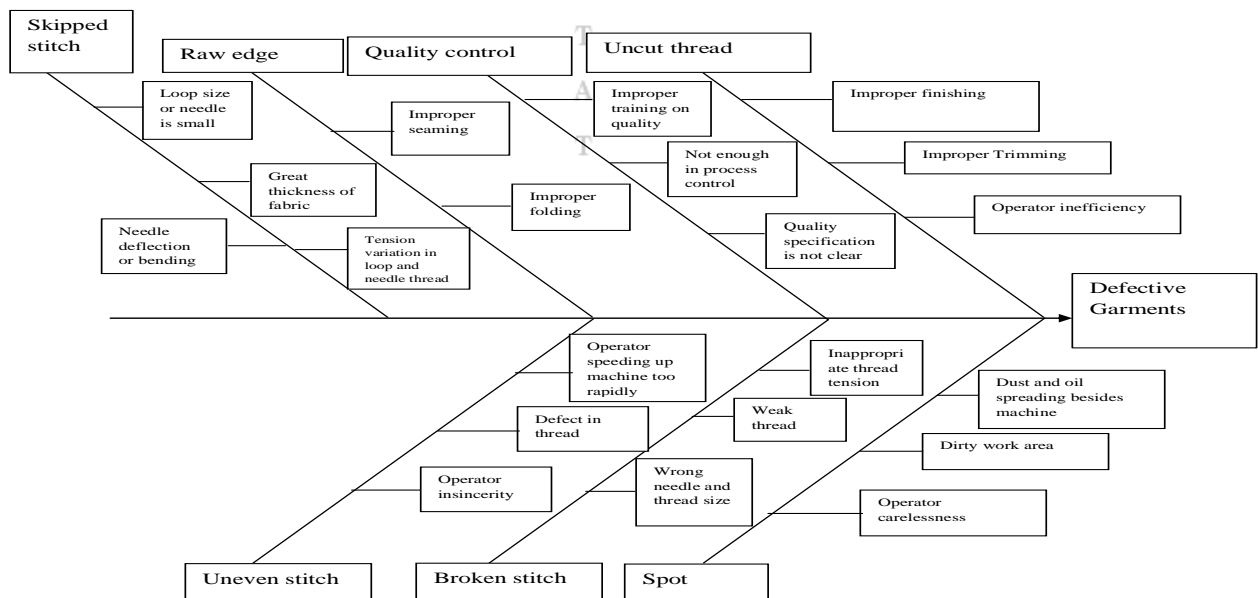

Figure 4. Fish bone diagram for defective garments

Table 2. Top 5 defects and action plan

Quality issue	Suggested solutions
Uncut thread	1. Improve quality inspection system. 2. Provide thread cutter to every operator and make used to.
Spot	1. Wash hands of operator before starting work and after lunch, establish preventive maintenance. 2. Keep workplace neat and clean. 3. Clean machine properly twice in a day.
Quality control	1. Improve quality inspection system. 2. Clear quality specification.
Broken stitch	1. Tension of the thread properly adjusted. 2. Select good quality thread which is free from flaws. 3. Needle size and thread size should be synchronized.
Raw edge	1. Improve or change folding system. 2. Teach operator.
Uneven stitch	1. Control the speed of machine, use right needle and correct feed control. 2. Never pull on the fabric while sewing, let it be taken up by the machine.
Skipped stitch	1. Reduce gap between presser foot and the hole of needle plate. 2. Timing and hook or lopper with needle should be adjusted properly. 3. Adjust tension properly.

The existing 5S score of the sewing floor was 1.83. To increase the working environment as well as 5S score some corrective actions were taken. These corrective actions are listed below:

1. Removal of unnecessary items
2. Displaying MSDS and SOP
3. Material storage review
4. Stretcher not to be blocked
5. Easy access to first aid box
6. Checking trays coming way
7. Proper Operator movement

8. Floor cleaning
9. Cleaning Machines
10. 5S audit

4. DATA ANALYSIS

J
T
A
T
M
Efficiency is the comparison of what is actually produced or performed with what can be achieved. In general terms efficiency is the percentage of output by input. In sewing floor the equation for efficiency is given bellow:

$$\text{Efficiency} = \frac{\text{Total output per day per line} \times \text{SMV}}{\text{Total manpower per line} \times \text{Total operating minute}} * 100 \quad (1)$$

Table 3. Day by day observed output of the line

Day	23-Nov	24-Nov	25-Nov	26-Nov	27-Nov
Output	259	280	270	295	312

The observed outputs of the line for that week are given to the Table 3.

Efficiency before implementing Kaizen:

Total output per line / day = 259 pcs, SMV = 37, Total manpower = 32, Total working minute = 10 hr = 10 × 60 minutes, by using equation (1), Efficiency = 50%

Efficiency after implementing Kaizen:

Total output per line / day = 312 pcs. SMV = 37, Total manpower = 31, Total working minute = 10 hr = 10 × 60 minutes, by using equation (1), Efficiency = 62%. Similarly the calculated efficiency of each day of the week is given in Table 4.

Table 4. Day by day observed efficiency of the line

Day	23-Nov	24-Nov	25-Nov	26-Nov	27-Nov
Efficiency (%)	50	56	54	59	62

DHU is the total no. of defects found in all the inspected garments in hundred units. DHU is considered as the total no of

defected points of all defect garments. DHU is an important quality indicator.

$$DHU = \frac{\text{Total no.of defects of inspected products}}{\text{No.of inspected products}} * 100 \quad (2)$$

On the first day, the total no. of inspected garments was 259 and the total no. of defect points was 347. By using Equation (2), DHU can be found to be 134. After taking

the corrective actions defects are reduced. Here it is noticed that DHU is reduced by taking the corrective actions of defects. The DHU for that week is given in table 5.

Table 5. DHU chart of the week

Day	23-Nov	24-Nov	25-Nov	26-Nov	27-Nov
DHU	134	118	143	92	51
No. of Defect points	347	330	386	271	159
No. of inspected products	259	280	270	295	312

The existing 5S score of the sewing floor was 1.83. The details of 5S score after Kaizen implementation are listed in Table 6.

After taking corrective actions, 5S score has been increased from 1.83 to 3.17.

Table 6. 5S score sheet after kaizen implementation

Sl. No.	Factors	Score	Note for the next level of improvement
01	Unnecessary Items	3	1. Unnecessary fabrics are present 2. Unnecessary yarns are present
02	Safety	4	1. Large items are stored incorrectly
03	Material Storage	3	1. Defective garments are stored in the tray 2. Unnecessary fabrics are stored
04	Tools & Gages	4	1. Tools are not standardized
05	Cleaning Equipment & Materials	4	1. No specific color code for brooms

06	Emergency Equipment	3	1. Emergency equipment are not colored 2. Not sufficient equipment
07	Aisles	3	1. Unnecessary yarns are present in the aisles 2. Fabrics are present in the aisles
08	Floor Cleaning)	3	1. Fabrics are present in the floor 2. Unnecessary yarns are found
09	Equipment (Cleanliness)	3	1. Unnecessary oil is always in the equipment 2. Work surfaces are not clean
10	Equipment (maintenance)	5	-
11	Visual Management	2	1. Not correctly specific 2. Is not updated Hourly 3. Congested area, tough to visualize
12	5S Control (Posted)	3	1. Counter measures implemented 2. Results are not graphed
Total		38	
5S Score		38/12 = 3.17	

During implementing kaizen, the observed Work-in-progress are given in table 7. The WIP has lessened gradually. This happened because of total productive maintenance of

operators and equipment. Mentoring, control and improvement in processes have resulted in this reduction of WIP.

Table 7. Observed WIP during implementing Kaizen

Day	23-Nov	24-Nov	25-Nov	26-Nov	27-Nov
WIP	152	145	133	121	106

5. RESULTS AND DISCUSSION

It was noticed that before Kaizen implementation the efficiency was 50%. Figure 5 exhibits that after implementing Kaizen the efficiency was increased in the first day but the next day the efficiency was fallen down. After that day the efficiency was increased gradually. Here the main cause was that Kaizen change the existing process and remove unnecessary activities and try to improve. But the main problem was that nobody is habited to change the existing process.

Before implementing Kaizen 5S score was 1.83. Here the 5S score was based on twelve important factors of garment environment. A new approach named visualization system has been introduced there. The present condition of output hour by hour is

J
T
A
T
M

visualized. The number of defects and most defects are also visualized. So the result is that the competition among worker increased. If there is also a system for extra incentive for good performance, operator will also be motivated. Actually the performance of output highly depends on the working environment. Improving the working environment by making it clean and worker friendly, the operators have become self-motivated to concentrate to the work. So the output of the operators has been increased automatically. In other word productivity depends on operators psychological factors. Before implementing Kaizen the 5S score was 1.83 but after implementing, monitoring, and controlling 5S approach the 5S score gets 3.17. Bangladeshi garments are usually hundred percent exports oriented. Buyer requirement

is to have the hundred percent quality products. But defects are common in sewing floors and it cannot be fully eliminated. After analyzing cause and effect diagram, it is found that few defects are common and occur maximum time. The root causes of those defects have been identified and

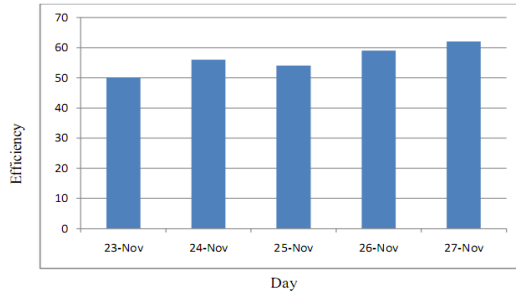

Figure 5. Observed day by day efficiency

The visualization system was introduced in the line. The hour by hour output, the total numbers of defects, top five defective operators, and the defect quantity have been showed in the visualization system. So the line supervisor could easily identify the problems and could take corrective actions to reduce those problems. If the visualization system is monitored properly, the DHU will also reduce more in future operations. Before implementing Kaizen work in progress (WIP) of garments was 152 shows in Figure 7. After implementing Kaizen work in progress (WIP) garments were reduced to 106. This WIP has reduced

corrective actions have been taken then the DHU has reduced rapidly. Before implementing Kaizen the DHU was 134 but after implementing Kaizen the DHU has turned to 51. Figure 6 exhibits the day by day reduction in DHU with the implementation of Kaizen.

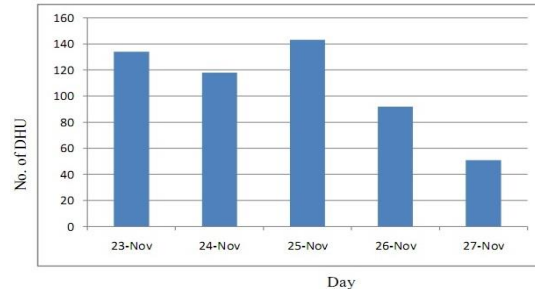

Figure 6. Reduction in DHU day by day

because of improvement in working environment and processes and so as efficiency, reduction in defects, and total productive maintenance (TPM) introduced for both machine and operators. All the works for the line were distributed equally such as line supervisor, water spider and operators. So monitoring in line has been better than pre Kaizen and WIP thus has been reduced. Figure 7 exhibits the day by day reduction in WIP with the implementation of Kaizen and Table 8 summarizes the overall results of Kaizen implementation.

J
T
A
T

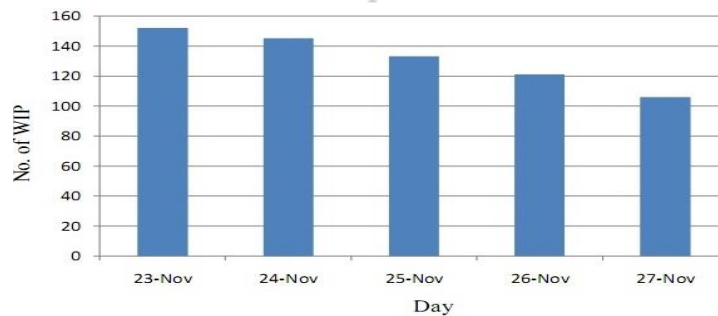

Figure 7. WIP reduction while implementing kaizen

Table 8. Outcomes of Kaizen implementation

Sl.	Objectives	Before KAIZEN implementation	After KAIZEN implementation	Result
1	DHU	134	51	62% reduced
2	5S Score	1.83	3.17	Increase by 1.34
3	WIP	152	106	30% down

6. CONCLUSIONS

The power of teamwork and collaboration is explored in shop floor kaizen break through (SKB) approach. The SKB was a 5 days activity which started from a small area to improve the overall productivity, efficiency and quality. The results of before Kaizen implementation and after Kaizen implementation are surprisingly fruitful. After implementing Kaizen DHU reduces from 134 pieces to 51 pieces, 5S score improves from 1.83 to 3.17, and WIP reduces from 152 to 106. The working environment has been tremendously improved as well. At the end of the week, dramatic operational improvements have been achieved. However, a 30-days action for future improvements has been identified to implement for the line. Motivating plans (incentives, prizes, training etc.) could be prepared to increase operators' performance. Operators training plan could be prepared to provide adequate training on lean manufacturing and Kaizen. The training plan must be reviewed. For team based working team leaders could be introduced.

But it is a matter of great concern that most of the industries in Bangladesh are not conscious and even they don't know the techniques about implementing Kaizen and its benefits. Bangladeshi garments industries have the low cost labor, but they could not make the highest profit because of not implementing new techniques such as lean, kaizen, 5S. Some apparel industries using these techniques are in the leading position. In modern competitive market implementation of Kaizen or continuous improvement is badly needed.

7. REFERENCES

1. Export Promotion Bureau. (2007). Bangladesh Export Statistics, Export Promotion Bureau, Dhaka. Available at www.epb.gov.bd/images/publication/Bangladesh_Export_Statistics%202006-2007_PDF%20file.pdf
2. Ferdousi, F. and Ahmed, A. (2009). An Investigation of Manufacturing Performance Improvement through Lean Production: A Study on Bangladeshi Garment Firms. *International Journal of Business and Management*, 4(9), 106-116.
3. Hall, K. W. (2013). Process Improvement through Established Standard Work. *Technology Interface International Journal*.
4. Hojjati, S.M.H. (2011). Implementing 5s System in Persia Noor Factory. *International Journal of Industrial Engineering*, 18(8), 425-431.
5. Kaur, M. (2014). Kaizen Costing: A catalyst for Change and Continuous Cost Improvement. *GE - International Journal of Management Research*.
6. Kumar, C.S.C. and Naidu, NVR. (2012). Minimizing the Eighth Waste of Lean-Absenteeism through Six Sigma Methodology. *International Journal for Quality research*.
7. Mohiuddin, M. (2009). Bangladesh As An Emerging Tiger In Apparel Market: Challenges And Strategies, Available at <http://www.scribd.com/doc/11536639/Bangladesh-as-an-Emerging-Tiger-in-Apparel-Market-Challenges-and-Strategies-By-Muhammad-Mohiuddin>

J
T
A
T
M

8. Singh, J. and Singh, H. (2009). Kaizen Philosophy: A Review of Literature. The Icfai University Journal of Operations Management, 8(2), 51-72.
9. United Nation Industrial Development Organization. (2009). Sustainable Exports of Ready-Made Garments in a New Competitive Environment, Available at <http://www.unido.org/index.php?id=953>
10. Womack, J.P., Roos, D., and Jones, D.T. (1990). The Machine That Changed the World, 1st edition, Harper Perennial, New York.
11. World Trade Organization. (2008). Trade Profiles 2008, WTO Publications, Geneva. Available at http://www.wto.org/english/res_e/booksp_e/anrep_e/trade_profiles08_e.pdf

J
T
A
T
M